

# Shear Magic

PROFESSIONAL



## Instruction Manual

# Tuffy 3800i Cordless Clipper

PLEASE REFER TO THIS INSTRUCTION MANUAL BEFORE USE



PO BOX 260 BOTANY NSW 1455  
Email: [info@botanybayimports.com.au](mailto:info@botanybayimports.com.au)  
Website: [www.shearmagic.net.au](http://www.shearmagic.net.au)  
ABN 31 128 341 980

Ph: 02 4624 8950

# Specifications

<b>Model</b>	T3800i- Tuffy3800 Cordless Commercial Clipper
<b>Dimension</b>	191×47×44mm (L×W×H)
<b>Weight (without blade)</b>	360g
<b>Watt</b>	24W
<b>Battery Type</b>	Li-ion Battery 7.4V Nominal Capacity: 3200mAh
<b>Adaptor</b>	Input: AC100-240V Output: DC 12V/2A
<b>Running time</b>	Up to 4hrs on low speed Up to 3hrs on high speed
<b>Strokes Per minute</b>	3,000 and 3,800
<b>Body Material</b>	PAG + Glass Fibre
<b>Material of blade</b>	High Carbon Steel
<b>Accessories</b>	Instruction manual, adaptor, cleaning brush, lubricant, battery pack, charging stand

## Component Names

1. Clipper body
2. Blade set
3. Switch ON/OFF
4. Light indication
5. Battery
6. Charging indication
7. Power switch socket

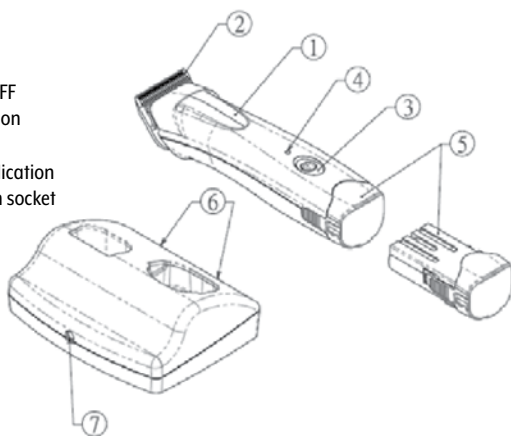

# Battery Level Signal

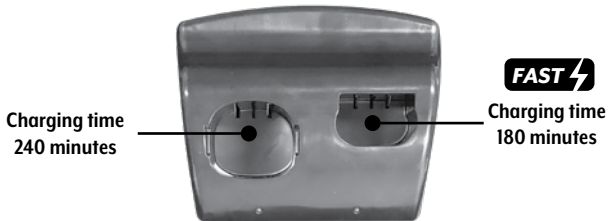

Clipper-Operation			
Low speed	High speed	Low battery	Overload
Red light on constant	Green light on constant	Red light flashing	Red light quickly flashing

Charge station		
Low speed	Fully Charged	Error
blue light flashing	blue light on constant	Red light flashing

After the battery is placed in the adaptor plug, it takes 3 seconds to detect before it can start charging. Charging base must only be supplied at SELV.

1. The battery is at low capacity when the red LED is flashing slowly. Please recharge the clipper or battery.
2. When the red LED blinks quickly, please remove all the attached power supplies and restart the device. The user should lubricate the blade if the LED blinks again. If error signs keep showing up, the user shall stop using the clipper and send it to the qualified maintenance service.
3. The red LED on the charging stand will flash when the batteries can not be charged correctly.

The LED will keep lighting up when the user turns on the clipper and plug in the power supply.

The user manual does not list some error signs for engineering purposes. If the device malfunctions and presents an error sign not listed in the manual, please send the clipper, including the power supply or the adapter, to the qualified maintenance service.

# Important Safeguards

When using the electrical appliance, basic precaution should always be followed.

## **DANGER** - to reduce the risk of electric shock:

1. Do not reach for an appliance that has fallen into water. Unplug immediately.
2. Do not use while bathing the animal.
3. Switch off/unplug the appliance when not in use and allow it to cool down before storing it in a safe place.
4. Do not lay metal objects across positive (+) and negative (-) battery terminals, charger terminals or clipper terminals
5. Keep unit dry at all times
6. Always return unit to the charging stand after using
7. Do not disassemble clipper
8. Make sure the local voltage is the same as adaptor input before charging.
9. Make sure clipper is switched off while charging.
10. During charging, the battery must be placed in a well-ventilated area.
11. Please do not use device near water 

## **WARNING** - to reduce the risk of burns, fire, electric shock or injury to persons:

1. An appliance should never be left unattended when plugged in.
2. Keep away from heated surfaces.
3. Keep the air openings free of hair, fur or the like.
4. Never drop or insert any object into any openings.
5. Do not wrap cord around unit when storing. Continuous stress on the charger cord can damage charging performance
6. Avoid contact with moving blades
7. Do not attempt to charge any battery pack or device other than intended Shear Magic battery
8. During use, do not place or leave the appliance where it is expected to:  
a. subject to damage by animal or b.exposed to weather
9. Do not discard exhausted battery packs into fire
10. This appliance is intended for clipping and trimming purposes only
11. Use only Shear Magic Professional genuine parts that are supplied by Botany Bay Imports
12. Store items at room temperature
13. Charge the Lio-Ion batteries prior to first use

14. Ensure that your clipper is serviced only by a qualified repair person
15. This appliance is not intended for use by persons (including children) with reduced physical, sensory or mental capabilities, or lack of experience and knowledge, unless they have been given supervision or instruction concerning use of the appliance by a person responsible for their safety.
16. Children should be supervised to ensure that they do not play with the appliance.
17. The appliance is only to be used with the power supply unit provided with the appliance
18. **WARNING:** Cutting blades may become hot after prolonged use.
19. **WARNING:** For the purpose of recharging the battery, only use the detachable supply unit provided with this appliance.
20. It must only be supplied at safety extra lower voltage corresponding to the markings on the appliance
21. **WARNING:** Keep the appliance dry
22. **WARNING:** For the purpose of recharging the battery, only use the detachable supply unit provided with this appliance.
23. The appliance is only to be used with the power supply unit provided. It must only be supplied at safety extra lower voltage corresponding to the markings on the appliance.
24. **WARNING:** For the purpose of recharging the battery, only use the authorised batteries with this appliance

## Operation

### BEFORE USE

1. Plug the power cord of the charging stand into an outlet with the rated voltage for your unit
2. Insert the battery into the charging station
3. Please charge battery prior to using.
4. Please charge the appliance for about 5 to 6 hours if the clipper has not used for over 2 months.
5. When the adaptor is connected to the charger the power indicator will light up.
6. The battery will perform better after 3 to 5 charges

### AFTER USE

1. Be sure the clipper is OFF.
2. Make sure to clean out the hair and lubricate the blade after using.
3. Use cleaning brush to clean the blade set, and hinge area of clipper.
4. Use oil (2-3 drops) to lubricate the blade sets.(only use clipper blade oil)

### TO REMOVE THE BLADE ASSEMBLY

Hold the unit in your hands and on the back of the clipper, just below the blade, there is a black metal latch. Push the latch up towards the blade while you are holding the latch in, gently pull the top of the blade away from the clipper.

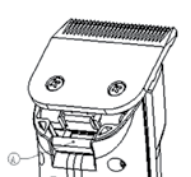

### TO REPLACE THE BLADE ASSEMBLY

Turn the control switch to the ON position. Holding the blade assembly by the sides to keep fingers away from the cutting position the blade on the hinge (tongue). Push forward to lock into place. Latching is automatic.

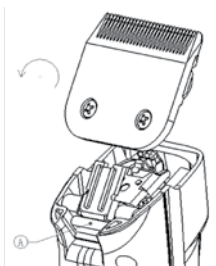

### REMOVING DIRT AND HAIR

Occasionally, dirt and hair will lodge between the blade and comb forcing them apart and stopping the cutting action. Remove the blade assembly, as described above.

Push the blade sideways from its position under the metal clip. See illustrations. Remove the dirt and hair. Then slide, the blade back into position.

**NOTE:** There is no need to remove the screws on the tension spring when removing dirt and hair.

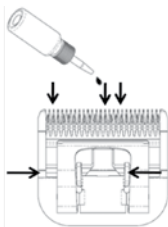

## Maintenance

### CLEANING AND STORING

1. Disconnect the charging station from the power supply
2. If necessary, remove hairs from both charging stations
3. If dirty clean the contacts with a dry cloth
4. Make sure all blades are oiled once storing blades away. If not oiled this causes blades to cease.

### SHARPENING BLADES

After extended use, the blades will begin to lose factory cutting edge and will need resharpening. To avoid the loss of clipping time, you may wish to keep a spare set of blades on hand. Contact Botany Bay Imports for blade re-sharpening information 02 4624 8950 or [www.botanybayimports.com.au](http://www.botanybayimports.com.au)

## **OILING THE BLADE ASSEMBLY**

Apply oil directly on the cutter blade just 1-2 drops. Use clipper blade oil only.

## **CLIPPER SERVICE**

Your clippers should be serviced on a regular basis for an authorized service centre please contact: Botany Bay Imports 02 4624 8950 or [www.botanybayimports.com.au](http://www.botanybayimports.com.au)

# **Battery**

## **FOR RECHARGE IN THE APPLIANCE**

- Assembled with a Li-ion battery.
- If not using for a long period, recharge and use the clipper once three months to expand the battery's lifespan
- **WARNING:** Do not attempt to charge any battery pack or device other than intended Shear Magic battery.
- **WARNING:** Only use genuine Shear Magic Lithium-Ion batteries. Do not use non-rechargeable batteries.
- To ensure the lithium-ion battery reaches its full potential, the battery should be drained after the first use. It will take more than 180 minutes for the battery to be fully charged when fully discharged.
- When the battery is fully charged, the clipper can be used for up to 240 minutes

## **FOR RECHARGE OUT OF THE APPLIANCE CHANGING THE BATTERY**

- Move the switch into the off position
- Push the battery interlock on both sides inward and pull the battery out of the clipper.
- Fit the charged battery in the clipper, till the battery interlock is engaged on both sides.
- Use only the original Shear Magic charging station, other charging stations could cause your batteries to become faulty.
- When the charger is not in use, remove stand from power supply.
- Never use damaged batteries. dispose of these immediately.
- Batteries are to be inserted with correct polarity (+-)
- Exhausted batteries are to be removed from the appliance and safely disposed off.
- If the appliance is to be stored unused for a long period, the batteries are removed
- The supply terminals are not to be short-circuited.

## LEAKING BATTERIES:

- Place leaking or damaged batteries in a clear plastic bag and take them to a waste management centre or hazardous household waste collection point for disposal.
- Wash your hands thoroughly with soap and water once dealing with leaked battery. In case of eye contact, seek medical attention immediately.



Do not dispose of batteries and clippers with household items. Do not throw batteries into fire or water. Defective or exhausted batteries and clipper must be collected and recycled or disposed of in environmentally compatible ways according to national, regional and local news, regulations and directives.

## Optional Blades

There are optional blades available for your Shear Magic Tuffy 3800i

- This clipper takes Oster® A5 Type Blade sets which includes Shear Magic® Ceramic Blades, Shear Magic® Steel Blades and our Shear Magic Wide Blades®.
- These Clippers also take other major competitor blades



# Basic Trouble Shooting

MALFUNCTION	CAUSE	RECTIFICATION
Blade does not fit onto the clipper	Blade is not engaged	Slide the blade on the hinge/tongue, turn your clipper on and push the blade down and snap the hinge assembly closed. This will ensure the proper engagement of the blade on the driving tip. If you have any further questions, please call us.
Clipper does not turn on	Battery flat	Charge battery as per instructions
	Contacts dirty	Switch clipper off and clean contact on both charging unit and battery
	Faulty battery	If under warranty send back to authorised warranty service agent. If not under warranty spare parts are available
	Smell of burning from the motor	Motor may need replacing
	Clipperhead full of hair	Clean and oil clipperhead





## THE TUFFY 2 YEAR WARRANTY

Tuffy 3800 Cordless clipper comes with a 2 year warranty from date of purchase against any manufacturing fault. Lithium Ion Batteries only come with 12 month warranty against manufacturing fault

As you would expect, the warranty does not cover the following:

- Normal wearing parts (lever, latch, hinge, nameplate, bearings, housing, blade etc)
- Repairs or disassembly attempted by anyone other than an authorised service centre
- Repairs made due to normal wear and tear, abuse, improper maintenance, or dropping.
- Any alterations made to the unit.
- Damage due to blade coolants or other chemicals.
- Damage resulting from shipping or transit.

For warranty work, please visit [www.botanybayimports.com.au](http://www.botanybayimports.com.au) for a list of service and warranty agents. When sending warranty work to an agent please include a proof of purchase. Please check our trouble shoot guide to ensure it is not a common or easy to solve problem.

The product that is sent in for warranty that is over 6 months old and up to 2 years old, warranty parts will be replaced but where the products has done a lot of work a service charge will be applied.

Our goods come with guarantees that cannot be excluded under the Australian Consumer Law. You are entitled to a replacement or refund for a major failure and for compensation for any other reasonably foreseeable loss or damage. You are also entitled to have the goods repaired or replaced if the goods fail to be of acceptable quality and the failure does not amount to a major failure.

Inward postage is to be paid by the customer. Return postage will be paid on all warranty repairs. As part of all repairs, blades will also be sharpened for a nominal charge, as this is the most common cause of poor performance.

# Shear Magic

PROFESSIONAL



REGISTER YOUR PRODUCT ONLINE: [WWW.SHEARMAGIC.NET.AU](http://WWW.SHEARMAGIC.NET.AU)

Warranty registration on the internet or via return of the warranty registration card is required within 30 days (thirty days) of the purchase date for coverage of the equipment. Visit [www.shearmagic.net.au](http://www.shearmagic.net.au)

## SERVICE INFORMATION

If maintenance service or service under warranty is required, please call 02 4624 8950 or visit [www.botanybayimports.com.au](http://www.botanybayimports.com.au) for a list of repairers.

When returning the product for service or warranty please ensure the following:

- Postage is prepaid
- Use sturdy packaging to protect the product against damage in transit - such damage is not covered by the warranty
- Include your name, address and proof of purchase
- Provide a detailed description of the fault
- When sending a clipper do send the blades - but not attached to the clipper to avoid damage in transit.

Product: **Shear Magic**

Model: **Tuffy 3800i Cordless Clipper**

Customer Name:

Address:

Phone:

Email:

Date of Purchase:

Reseller: