

Shear Magic
PROFESSIONAL



Instruction Manual
Tuffy 5 in 1
Cord/Cordless Trimmer

PLEASE REFER TO THIS INSTRUCTION MANUAL BEFORE USE



PO BOX 260 BOTANY NSW 1455
Email: info@botanybayimports.com.au
Website: www.shearmagic.net.au
ABN 31 128 341 980

Ph: 02 4624 8950

Specifications



Model	T5in1 – Tuffy5in1 5 in 1 Cord/Cordless Trimmer
Dimension	180X49X46 (LxWxH)
Weight (without blade)	248g
Watt	12W
Battery Type	Li-ion Battery
Adaptor	DC Switching power supply 5V/2.5A
Working time	approx. 150min
Strokes Per minute	5,500
Coating of clipper housing	ABS
Material of blade	High Carbon Steel - Ceramic
Accessories	Instruction manual, power supply, cleaning brush, and lubricant

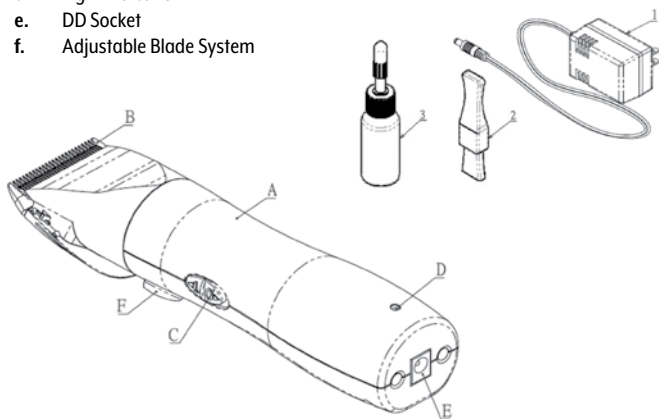

Component Names

- a. Clipper Body
 - b. Blade Set
 - c. Switch On/Off
 - d. Light Indication
 - e. DD Socket
 - f. Adjustable Blade System
- 1. POWER SUPPLY
 - 2. CLEANING BRUSH
 - 3. OIL



Light Indication

Power Indicator		
Charging	Fully Charged	Motor Running
		
Blue Light Flashing	Blue LED Light Up	Blue LED Light Up

Warning Sign		
Low battery	Overloading	Charging Fault
		
Red Light Flashing Slowly	Red Light Flashing Urgently	Red and Blue LED Flashing Alternately

After the battery is placed in the adaptor plug, it takes 3 seconds to detect before it can start charging.

Red Light Flashing Slowly

Please charge the clipper if the red LED light is flashing slowly.

Red Light Flashing Urgently

Please remove the attached power and turn off the clipper when the motor stop and the red light flashes urgently.

Clean the blades and lubricate them with oil. Then, turn the clipper on again.

If the clipper still malfunctions, please send the clipper to a qualified agent for maintenance.

Red and Blue LED Flashing Alternately While Charging

Please remove the power supply or adapter that is attached to the clipper.

Please clean the charging port on the clipper body and the slot on the charging base. Recharge the clipper again and check if the clipper starts to be charged successfully. If the error sign constantly shows again, please send the device to the qualified retailer or maintenance service.

Important Safeguards

When using the electrical appliance, basic precaution should always be followed.

DANGER - to reduce the risk of electric shock:

1. Do not reach for an appliance that has fallen into water. Unplug immediately.
2. Do not use while bathing the animal.
3. Switch off/unplug the appliance when not in use and allow it to cool down before storing it in a safe place.
4. Do not lay metal objects across positive (+) and negative (-) battery terminals, charger terminals or clipper terminals
5. Keep unit dry at all times
6. Always return unit to the charging stand after using
7. Do not disassemble clipper
8. Make sure the local voltage is the same as adaptor input before charging.
9. Make sure clipper is switched off while charging.
10. Please do not use device near water 

WARNING - to reduce the risk of burns, fire, electric shock or injury to persons:

1. An appliance should never be left unattended when plugged in.
2. Keep away from heated surfaces.
3. Keep the air openings free of hair, fur or the like.
4. Never drop or insert any object into any openings.
5. Do not wrap cord around unit when storing. Continuous stress on the charger cord can damage charging performance
6. Avoid contact with moving blades
7. Do not attempt to charge any battery pack or device other than intended Shear Magic battery
8. During use, do not place or leave the appliance where it is expected to:
a. subject to damage by animal or b. exposed to weather
9. Do not discard exhausted battery packs into fire
10. This appliance is intended for clipping and trimming of animal only
11. Use only Shear Magic Professional genuine parts that are supplied by Botany Bay Imports
12. Store items at room temperature
13. Charge the Lio-Ion batteries prior to first use
14. Ensure that your clipper is serviced only by a qualified repair person
15. This appliance is not intended for use by persons (including children) with reduced physical, sensory or mental capabilities, or lack of experience and knowledge, unless they have been given supervision or instruction concerning use of the appliance by a person responsible for their safety.

16. Children should be supervised to ensure that they do not play with the appliance.
17. The appliance is only to be used with the power supply unit provided. It must only be supplied at safely extra lower voltage corresponding to the markings on the appliance.
18. **WARNING:** Cutting blades may become hot after prolonged use.
19. **WARNING:** For the purpose of recharging the battery, only use the authorised batteries with this appliance.
20. **WARNING:** Keep the appliance dry
21. This appliance contains batteries that are only replaceable by skilled persons
22. **WARNING:** For the purpose of recharging the battery, only use the detachable supply unit provided with this appliance.

Operation

BEFORE USE

1. Plug the power supply into the charging socket of the clipper
2. Please charge the clipper for about 3 to 4 hours prior to using.
3. When the adaptor is connected to the charger the power indicator will light up. A flashing light will appear during charge. A blue steady light means the clipper is fully charged.

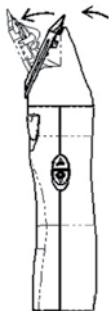

Fig 1

AFTER USE

1. Be sure the clipper is OFF.
2. Make sure to clean out the hair and lubricate the blade after using.
3. Use cleaning brush to clean the blade set, and hinge area of clipper.
4. The blade set can be removed by sliding it away from the housing in the direction of arrow (Fig 1)
5. Use oil (2-3 drops) to lubricate the blade teeth. (Only use clipper blade oil) (Fig 3)



Fig 2

BATTERY & BLADE

If you haven't used your clipper in over 3 months. It is recommended that you discharge then fully charge the battery.



For best cutting performance it is important to brush out any hair using a cleaning brush and to oil the blades before, during and after use.

SHARPENING BLADES

After extended use, the blades will begin to lose factory cutting edge and will need sharpening. To avoid the loss of clipping time, you may wish to keep a spare set of blades on hand. Contact Botany Bay Imports for blade re-sharpening www.botanybayimports.com.au

CLIPPER SERVICE

Your clippers should be serviced on a regular basis for an authorized service centre please contact: Botany Bay Imports - www.botanybayimports.com.au

Battery

- Assembled with the Li-ion battery.
- If not using for a long period, recharge and use the clipper once three months to expand the battery's lifespan
- **WARNING:** Only use genuine Shear Magic batteries suitable for this model.
- To ensure the lithium-ion battery reaches its full potential, the battery should be drained after the first use. It will take more than 120 minutes for the battery to be fully charged when fully discharged.
- When the battery is fully charged, the clipper can be used for up to 180 minutes

CHANGING THE BATTERY

- Send the unit to an authorised service agent.



Do not dispose of batteries and clippers with household items. Do not throw batteries into fire or water. Defective or exhausted batteries and clipper must be collected and recycled or disposed of in environmentally compatible ways according to national, regional and local news, regulations and directives.

Basic Trouble Shooting

MALFUNCTION	CAUSE	RECTIFICATION
Blade set is unable to fit onto the clipper	Slot of blade and moving blade do not fit well	Push the blade lightly to the middle location
Clipper does not turn on	Battery flat	Charge battery as per instructions
	Smell of burning from the motor	Motor may need replacing
	Adaptor voltage	Change the adaptor
	Motor	Motor may need to be replaced
	Clipperhead full of hair	Clean and oil clipperhead
	Blade sharpness	Change the blade set

Optional Blades

- Contact Botany Bay Imports for optional blades



THE TUFFY 2 YEAR WARRANTY

Tuffy 5 in 1 Cord/Cordless Trimmer come with a 2 year warranty from date of purchase against any manufacturing fault. Lithium Ion Batteries only come with 12 month warranty against manufacturing fault

As you would expect, the warranty does not cover the following:

- Normal wearing parts (lever, latch, hinge, nameplate, bearings, housing, blade etc)
- Repairs or disassembly attempted by anyone other than an authorised service centre
- Repairs made due to normal wear and tear, abuse, improper maintenance, or dropping.
- Any alterations made to the unit.
- Damage due to blade coolants or other chemicals.
- Damage resulting from shipping or transit.

For warranty work, please visit www.botanybayimports.com.au for a list of service and warranty agents. When sending warranty work to an agent please include a proof of purchase. Please check our trouble shoot guide to ensure it is not a common or easy to solve problem.

The product that is sent in for warranty that is over 6 months old and up to 2 years old, warranty parts will be replaced but where the products has done a lot of work a service charge will be applied.

Our goods come with guarantees that cannot be excluded under the Australian Consumer Law. You are entitled to a replacement or refund for a major failure and for compensation for any other reasonably foreseeable loss or damage. You are also entitled to have the goods repaired or replaced if the goods fail to be of acceptable quality and the failure does not amount to a major failure.

Inward postage is to be paid by the customer. Return postage will be paid on all warranty repairs. As part of all repairs, blades will also be sharpened for a nominal charge, as this is the most common cause of poor performance.

Shear Magic

PROFESSIONAL



REGISTER YOUR PRODUCT ONLINE: WWW.SHEARMAGIC.NET.AU

Warranty registration on the internet or via return of the warranty registration card is required within 30 days (thirty days) of the purchase date for coverage of the equipment. Visit www.shearmagic.net.au

SERVICE INFORMATION

If maintenance service or service under warranty is required, please call 02 4624 8950 or visit www.botanybayimports.com.au for a list of repairers.

When returning the product for service or warranty please ensure the following:

- Postage is prepaid
- Use sturdy packaging to protect the product against damage in transit - such damage is not covered by the warranty
- Include your name, address and proof of purchase
- Provide a detailed description of the fault
- When sending a clipper do send the blades - but not attached to the clipper to avoid damage in transit.

Product: **Shear Magic**

Model: **Tuffy 5 in 1 Cord/Cordless Trimmer**

Customer Name:

Address:

Phone:

Email:

Date of Purchase:

Reseller: